

Sequencing and Molecular Analysis of ATP 6 and ATP 8 of Mitochondrial Genome in Khorasanian Native Chickens

Research Article

A. Afsharian^{1*} and M.R. Nassiri¹

¹ Department of Animal Science, Ferdowsi University of Mashad, Mashad, Iran

Received on: 26 Aug 2014

Revised on: 7 Dec 2014

Accepted on: 15 Dec 2014

Online Published on: Dec 2015

*Correspondence E-mail: afsharian1975@gmail.com

© 2010 Copyright by Islamic Azad University, Rasht Branch, Rasht, Iran

Online version is available on: www.ijas.ir

ABSTRACT

In order to perform breeding programs and improve production of native chickens, preserving genetic diversity in different areas of Iran is important due to the reduced available population. Genome sequencing is considered the most functional approach to determine the phylogeny relation between close populations. The aim of the present study was the evaluation of the phylogeny and genetic nucleotide sequences of ATP 6 and a partial region of ATP 8 fragments in mitochondrial genome of khorasanian native chickens. For this purpose, blood samples were randomly collected from 6 khorasanian native chickens and after DNA extraction the ATP 6 and partial region of ATP 8 fragments with the length of 867 bp were amplified using specific primers. Sequencing was done according to Sanger method and based on automate system. The phylogeny tree and matrices of the genetic distances between khorasanian native chickens and other breeds for ATP 6 and ATP 8 of mitochondrial genome were drawn using the same sequences of mitochondrial genome in other available breeds in NCBI database. Results showed no haplotype difference between the studied samples sequences. Phylogeny test results revealed that khorasanian native chicken were similar to native chicken in Laos, White Leghorn and White Plymouth Rock. Further more, the lowest genetic distance was observed between khorasanian native chicken with *Phasianus colchicus* and *Tragopan caboti* for the ATP 6 and *Columba livia* and *Francolinus pintadeanus* for the ATP 8 genes.

KEY WORDS DNA mitochondrial, Khorasanian native chicken, phylogenic analysis.

INTRODUCTION

There are more than 100 native fowl genetic populations in Iran adjusted to different environmental conditions, with relative resistance to local diseases so that they are considered an important national asset. The native chickens are a genetic reserve to protect and preserve for the next generation, in need to be more extensively. Two hypothesis have been proposed for these domestic chickens: i) they are thought to be originated by *Gallusgallus*; ii) domestic chickens were derived from several gallus subclass (Crawford, 1990). To determine the phylogeny relationship between populations and species molecular approach such

as mitochondrial genome sequencing is considered as the most functional method (Bruford *et al.* 2003). Mitochondria is a cytoplasmic organ existing in most body cells. This organelle who is able to produce energy for the cells has a distinctive and independent nuclear DNA, encoding 37 genes in the animal species, including 13 genes encoding for the respiratory chain, 22 genes encoding tRNA and 2 genes encoding rRNA. Expressing these gene seems to be necessary in vertebrate because of their roles in energy producing, metabolism, hemostasis and cell death (DiMauro, 2004). Several advantages can be mentioned for the mitochondrial DNA (mtDNA), such as more than 1000 copies for each cell, small size comparing with genome DNA,

maternal heritability, no recombination and the ability to amplify using distinctive triggers, and finally the presence of protected and non protected regions sequencing for dependent species developmental studies (Bellagamba *et al.* 2001). The (Mitochondrial ATP6) MT-ATP6 protein forms one part (subunit) of a large enzyme called ATP synthase. This enzyme, which is also known as complex V, is responsible for the final step of oxidative phosphorylation (Anderson *et al.* 1981). The MT-ATP6 gene provides information for making a protein that is essential for normal mitochondrial function. Mitochondria are structures within cells that convert the energy from food into a form that cells can use. These cellular structures produce energy through a process called oxidative phosphorylation, which uses oxygen and simple sugars to create adenosine triphosphate (ATP), the cell's main energy source (Walker *et al.* 2005). ATP synthase protein 8 is a protein that in humans is encoded by the MT-ATP8 gene. It is a subunit of synthase. This subunit appears to be an integral component of the stator stalk in yeast mitochondrial F-ATPase. The stator stalk is anchored in the membrane, and acts to prevent futile rotation of the ATPase subunits relative to the rotor during coupled ATP synthesis / hydrolysis (Stephens *et al.* 2003). The purpose of this study was to analyze the phylogeny of ATP 6 and a partial region of ATP 8 mitochondrial DNA of Khorasanian native chickens.

MATERIALS AND METHODS

In this study blood, samples from Khorasanian native chickens were collected. In addition, 6 blood samples were collected from unrelated chicken to assess relationships. DNA was extracted using a commercial kit (Thermo, USA). The extracted DNA quantity and quality were measured according to spectrometry method using NANO-DROP-ND 2000 spectrophotometer (Thermo, USA) and agarose gel. Two sets of specific primers for amplifying ATP 6 and a partial region of ATP 8 fragments designed using the primer primer 5:

Forward: 5'-CCCAAACCCATGATTCTCC-3'

Reverse: 5'-GGCTTGGGTCAACTATGTGGTA-3'

Polymerase chain reaction (PCR) for amplifying ATP 6 and ATP 8 fragments was carried out using T-personal model Biometra thermocycler (Germany). The component of polymerase chain reaction in the final volume were included in 25 μ L PCR mixture containing 100 ng DNA, 0.2 unit *Taq* polymerase enzyme, 2 μ L dNTP (10 mM), 1.5 μ L MgCl₂, and 1 pmol gene specific of the primers (50 Mm). Also, in order to confirm the amplification, samples were electrophoresed on 1% agarose gel.

Also PCR program for ATP 6 gene was included at 94 °C for 30 s, annealing at 54 °C for 35 s, proliferation at 72 °C for 30 s, a primary step at 94 °C for 10 min and a final amplifying stage at 72 °C for 10 min on 35 cycle. In addition for ATP 8 gene the procedure was: 94 °C for 30 s, annealing at 56 °C for 35 s, proliferation at 72 °C for 30 s, a primary step at 94 °C for 10 min and a final amplifying stage at 72 °C for 10 min on 35 cycle. The PCR Products were then passed on electrophoresis on 1% agarose gel and coloration was performed using etidium bromide. PCR production was purified and sent with each used primers forward and reverse (10 pmol), to Macro Gen Company (south Korea) for sequencing. These samples are sequenced using the ABI3130 machine according to Sanger automate approach. The obtained sequences homology level was measured using accurate BLAST tool and blastn method in NCBI database. In order to study the phylogenetic relation between target breeds, we draw the phylogeny tree using the alignment sequences UPGMA approach by MEGA software.

RESULTS AND DISCUSSION

DNA was extracted successfully from all the samples and the spectrometry results confirmed their quality. Electrophoresis of amplified productions on agarose gel showed that the designed primers were amplified on ATP 6 and a partial region of ATP 8 fragments with 867 bp correctly (Figure 1).

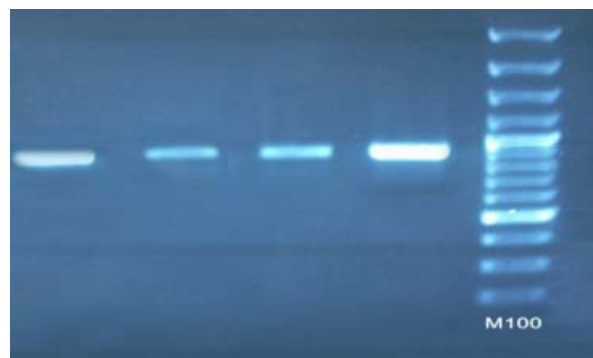

Figure 1 Electrophoresis of 867 bp PCR Products on 1% agarose gel

Sequencing of ATP 6 and ATP 8 regions were performed for 6 samples but one of the sample result was removed due to low quality. After samples sequencing using Glustamultiple alignment tool of Bio Edit software, the five samples were compared. The 684 and 142 fragments were used in all the samples as the census sequence for ATP 6, ATP 8 regions respectively, in such way that comparing the obtained sequence by these tools revealed that there is no difference between the studied sequences.

Probably this was the result from few samples number or an homogeneous mass, due to a permanent selection based on commercial goals in the course of several generations.

ATP 6 sequence nucleotide compound was calculated like as adenine 28%, cytosine 38%, guanine 10% and thymine 24%, indicating the 48% and 52% frequency for G + C and A + T respectively (Figure 2). Adenine cytosine, guanine and thymine frequencies were calculated for ATP 8 as 29%, 38%, 6%, 27% and the 44 and 56% frequency in relation to G + C and A + T, respectively (Figure 3).

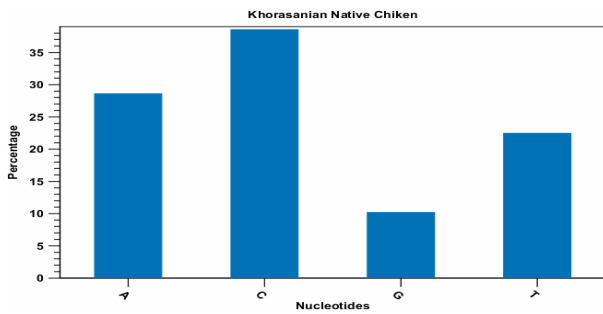

Figure 2 Frequency percentage for constituent nucleotides at ATP 6 consensus sequence

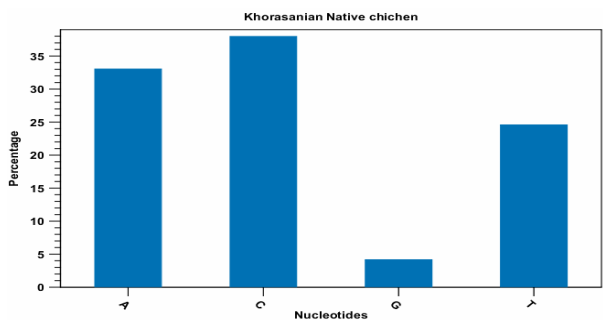

Figure 3 Frequency percentage for constituent nucleotides at ATP 8 consensus sequence

The nucleotide relative frequency in consensus sequences in these gene regions is very close to nucleotides percent in these regions of registered domestic chicken mtDNA in NCBI database.

Also comparing the under study sequences with registered sequences indicated that there are high overlapping and homology between these sequences and available sequences in this database.

These findings show that the sequenced region in this study was the same as the region in other studies. The results of studying the phylogenetic tree revealed that ATP 6 region's sequence of Khorasanian native chicken was closer to native chicken in Laos and White Leghorn. Furthermore, results show that the lowest similarity observed was between Khorasanian chickens with *Phasianus colchicus* and *Tragopan caboti* (Figure 4). Furthermore, the results of ATP 8 gene phylogenetic tree show that mitochondrial genome of Khorasanian native chicken are closer to White Leghorn and belong to a same group but more differences were observed between them with *Columba livia* and *Francolinus pintadeanus* breeds (Figure 5). The study of the ATP 6 region's genetic matrixes of mitochondrial genome of khorasanian native chickens, indicated the shortest genetic distance between khorasanian native chickens and native chicken in Laos, White Leghorn and White Plymouth Rock (Table 1). These results confirmed the drawn phylogenetic tree.

Matrix of ATP 8 region's genetic distances of mitochondrial genome indicated that the shortest genetic distance was between khorasanian native chickens and White Leghorn, White Plymouth Rock, Lvewv, Taoyuan and Huang Lang chickens equally zero and most distances was between them with *Columba livia* and *Francolinus pintadeanus*. Also these result confirm the drawn phylogeny tree (Table 2).

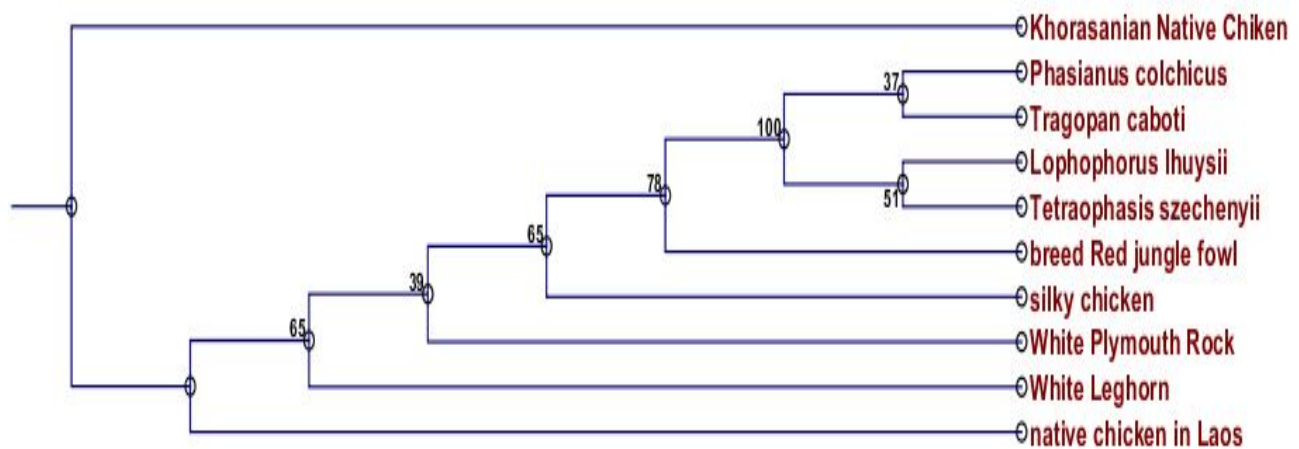

Figure 4 Phylogeny tree between ATP 6 consensus sequence of Khorasanian native chicken and other references

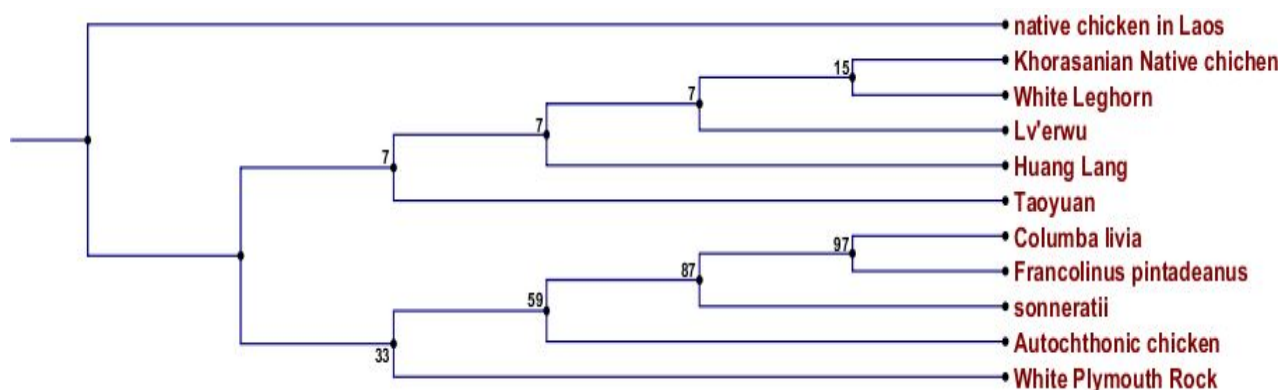

Figure 5 Phylogeny tree between ATP 8 consensus sequence of Khorasanian native chicken and other references

Table 1 Nucleotide similarities and differences matrix of ATP 6 gene in Khorasanian native chickens in relation to other references

	1	2	3	4	5	6	7	8	9	10	
Khorasanian native chicken	1	-	100.00	100.00	100.00	99.56	99.56	88.01	86.70	85.09	85.53
Native chicken in Laos	2	0	-	100.00	100.00	99.56	99.56	88.01	86.70	85.09	85.53
White Leghom	3	0	0	-	100.00	99.56	99.56	88.01	86.70	85.09	85.53
White Plymouth rock	4	0	0	0	-	99.56	99.56	88.01	86.70	85.09	85.53
Breed red jangle fowl	5	3	3	3	3	-	99.42	88.16	86.55	85.38	85.67
Silky chicken	6	3	3	3	3	4	-	87.87	86.26	84.94	85.38
Tetraophasis szechenyii	7	82	82	82	82	81	83	-	89.33	84.50	85.53
Lophophorus ihuysii	8	91	91	91	91	92	94	73	-	86.26	85.38
Tragopan caboti	9	102	102	102	102	100	103	106	94	-	85.92
Phasianus colchicus	10	99	99	99	99	98	100	99	100	110	-

Table 2 Nucleotide similarities and differences matrix of ATP 8 gene in Khorasanian native chickens in relation to other references

	1	2	3	4	5	6	7	8	9	10	11	
Native chicken in Laos	1	-	100.00	100.00	100.00	99.39	100.00	100.00	95.15	86.06	86.67	78.57
Taoyuan	2	0	-	100.00	100.00	99.39	100.00	100.00	95.15	86.06	86.67	78.57
Hoang lang	3	0	0	-	100.00	99.39	100.00	100.00	95.15	86.06	86.67	78.57
Lv'erwu	4	0	0	0	-	99.39	100.00	100.00	95.15	86.06	86.67	78.57
Autochthonic chicken	5	1	1	1	1	-	99.39	99.39	95.76	85.45	86.06	77.98
White Leghom	6	0	0	0	0	1	-	100.00	95.15	86.06	86.67	78.57
White Plymouth Rock	7	0	0	0	0	1	0	-	95.15	86.06	86.67	78.57
Sonneratii	8	8	8	8	8	7	8	8	-	81.21	86.06	78.57
Khorasanian native chicken	9	23	23	23	23	24	23	23	31	-	73.94	76.26
Francolinus pintadeanus	10	22	22	22	22	23	22	22	23	43	-	76.19
Columba livia	11	36	36	36	36	37	36	36	36	55	40	-

According to the phylogeny tree results and the study of the genetic distances for these two gene, we can conclude that using these two markers for showing the genetic distance between the Khorasanian native chicken and the other studied breeds is of extreme importance. Our results are similar to [Amaral et al. \(2006\)](#) finding and similar works has been done by [Liu et al. \(2010\)](#) and [Liu et al. \(2013\)](#).

CONCLUSION

These results indicate that the genetic diversity, from medium to low, can be observed in these populations.

Similarities in some of the polymorphic regions show the close genetic relationship between this population and other chicken breeds. Importing foreign modified breed chickens may lead to a decrease in the capacity of native chickens production. The use of genic methods can enhance production capacity due to the adjusting ability in regards to environmental conditions, their relative resistance to local diseases using ATP 6 and ATP 8 regions sequencing of mitochondrial genome indicating that these breeds are similar to high producing breeds in some ways, because of short length and easy methods to analyze the data and comparing it with some of the commercial breeds, suggesting that

there is the possibility to produce and disseminate these breeds. It should be noted that the sequence used would allow us to register our native chicken breeds in the world gene bank.

REFERENCES

- Anderson S., Bankier A.T., Barrell B.G., de Bruijn M.H., Coulson A.R., Drouin J., Eperon I.C., Nierlich D.P., Roe B.A., Sanger F., Schreier P.H., Smith A.J., Staden R. and Young I.G. (1981). Sequence and organization of the human mitochondrial genome. *Nature*. **290**, 457-465.
- Bellagamba F., Moretti V.M., Comincini S. and Valfare F. (2001). Identification of species in animal feedstuffs by polymerase chain reaction restriction fragment length polymorphism analysis of mitochondrial DNA. *J. Agric. Food Chem.* **49**, 3775-3781.
- Bruford M.W., Bradley D.G. and Luikart G. (2003). DNA markers re-veal the complexity of livestock domestication. *Nat. Rev. Genet.* **4**, 900-910.
- Crawford R.D. (1990). Origin and history of poultry species. Pp. 1-42 in *Poultry Breeding and Genetics*. R.D. Crawford, Ed. Elsevier, Amsterdam.
- DiMauro S. (2004). Mitochondrial diseases. *Biochim. Biophys. Acta*. **1658**, 80-88.
- Do Amaral F.S.R., Miller M.J., Silveira L.F., Bermingham E. and Wajntal A. (2006). Polyphyly of the hawk genera *Leucopternis* and *Buteogallus* (Aves, Accipitridae): multiple habitat shifts during the Neotropical buteonine diversification. *BMC Evol. Biol.* **6**, 10-18.
- Liu G.H., Shao R., Li J.Y., Zhou D.H., Li H. and Zhu X.Q. (2013). The complete mitochondrial genomes of three parasitic nematodes of birds: a unique gene order and insights into nematode phylogeny. *BMC Genomics*. **14**, 414.
- Liu G., Liu Y., Zhang H., Huang J. and Fang M. (2010). Genetic variations and sequences analysis of MTATP6 and MTATP8 genes among different Chinese pig breeds. *J. Anim. Breed. Genet.* **127**, 474-480.
- Stephens A.N., Khan M.A., Roucou X., Nagley P. and Devenish R.J. (2003). The molecular neighborhood of subunit 8 of yeast mitochondrial F1F0-ATP synthase probed by cysteine scanning mutagenesis and chemical modification. *J. Biol. Chem.* **278**, 17867-17875.
- Walker J.E., Runswick M.J., Neuhaus D., Montgomery M.G., Carbajo R.J. and Kellas F.A. (2005). Structure of the F1-binding domain of the stator of bovine F1Fo-ATPase and how it binds an alpha-subunit. *J. Mol. Biol.* **351**, 824-838.